



Main applications

- Extrusion lines and injection presses for plastics
- Hot channels
- Thermoforming machines
- Packing and packaging machines
- Temperature controllers for molds
- Electric kilns for ceramics and goldsmith's shop
- Machines for the food industry

Main features

- Logic signal input control
- Switching at voltage zero crossing.
- LED display of logic control state
- Overvoltage protection
- Faston connections
- Provision for DIN bar attachment, panel attachment and base attachment

PROFILE

The GTS-L series of solid state power units are miniaturized solid state relays, complete with heatsink, with zero-crossing.

They are available with currents up to 15A, rated voltages 230 VAC and 440 VAC, and input control from VDC logic signal.

All models have been designed to guarantee operation at rated currents, with continuous power, at 40°C.

Their characteristics make them suitable for very short switching times, with millions of operations without wear on components.

Connections are Faston-type, with optional connection for standard bases, for DIN guide or front panel attachment.

TECHNICAL DATA

General features

Category of use: AC1

Nominal voltage

- 230Vac (max. range 24...253Vac)

- 440Vac (max. range 24...484Vac)

Nominal frequency: 50/60Hz

Non-repetitive voltage:

- 500Vp for model with 230 VAC rated voltage

- 800Vp for model with 440 VAC rated voltage

Zero switching voltage: < 20V

Activation time: =1/2 cycle

Deactivation time: =1/2 cycle

Voltage drop at nominal current : = < 1.4Vrms

Power factor = 1

Control inputs

Max. input: 15mA @32V

Max. reverse voltage: 36Vdc

GTS-L 5/10/15

Control voltage: 3...32Vdc

Activation voltage: >2.55Vdc

Deactivation voltage: <1Vdc

OUTPUTS

GTS-L 5

Nominal current: 5A@40°C in continuous service

Non-repetitive overcurrent t=20ms: 80A

I²t for blowout: 45A²s

dV/dt critical with output deactivated: 500V/μs

GTS-L10

Nominal current:

10 A@40°C in continuous service

Non-repetitive overcurrent t=20 ms: 120A

I²t for blowout: 100A²s

dV/dt critical with output deactivated: 500V/μs

GTS-L15

Nominal current:

15 A@40°C in continuous service

Non-repetitive overcurrent t=20 ms: 160A

I²t for blowout: 180A²s

dV/dt critical with output deactivated: 500V/μs

Isolation

Rated isolation voltage input/output: 2500VAC rms

Ambient conditions:

- Working temperature: 0 to 80°C (see the dissipation curves)
- Max. relative humidity: 50% to 40°C
- Max. installation altitude: 2000m asl

- Pollution level: 3
- Storage temperature: -20..+85°C
- Internal use

Installation notes

Models with external heatsink must be grounded.

Use the high-speed fuse indicated in the catalog according to the connection example.

Applications with power solid state relays require an automatic safety cutout to disconnect the load power line.

For maximum reliability, install the device correctly in the panel to have sufficient heat exchange between the heatsink and the air under conditions of normal convection.

Mount it vertically (max. 10° inclination from the vertical axis)

- Vertical distance between a device and the panel walls >100mm
- Horizontal distance between a device and the panel walls: at least 20mm
- Vertical distance between devices: at least 300mm
- Horizontal distance between devices: at least 20 mm.

Make sure that the wire raceways do not reduce such distances: if they do, install the groups cantilevered to the panel so that air can flow vertically over the heat sink without obstructions.

Limits of use

- Dissipation of thermic power on the device with restraints on the ambient temperature of the installation.
- Equipe the cabinet with an external air change or air-condition it, to put out

dissipated power.

- Installation restraints (distances to be respected to grant dissipation with natural convection)
- Line transistor max. voltage and derivative limits, for which the solid state relay is equipped with inside safety devices (varistor).
- pLeakage current < 4mA for GTS-Ls. (max. value with rated voltage and junction temperature of 125°C).

FACEPLATE DESCRIPTION

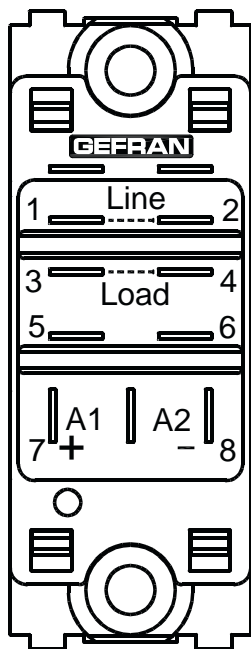

- 1,2: Line faston connection
- 3,4: Load faston connection
- 7: Control signal (-)
- 8: Control signal (+)

WORKING TYPOLOGY

Voltage logic output control

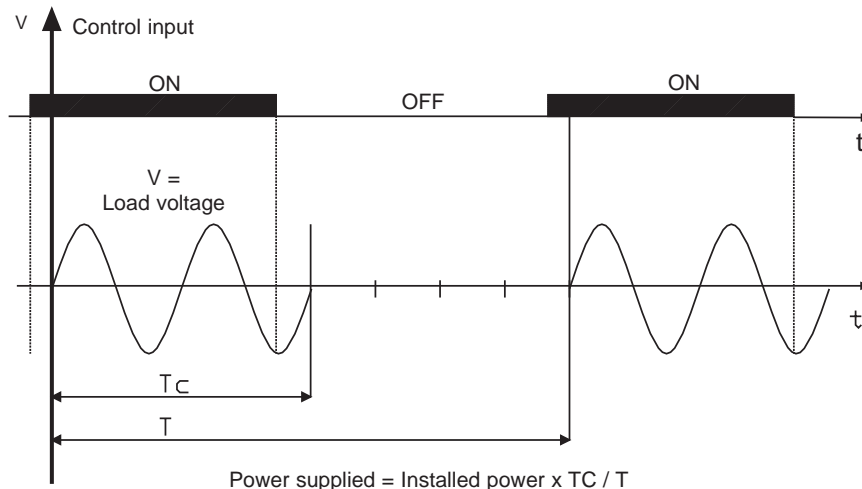

MOUNTING DIMENSIONS

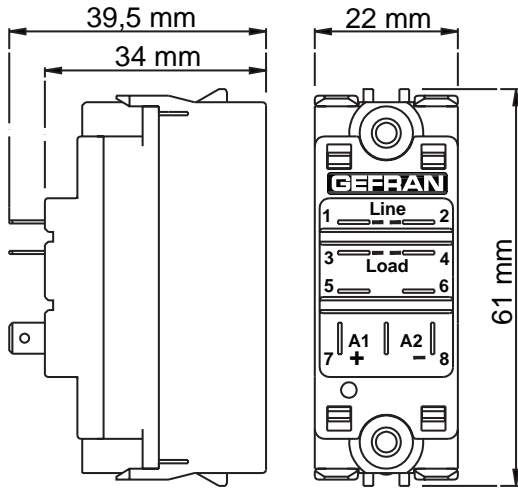

GTS-L 5

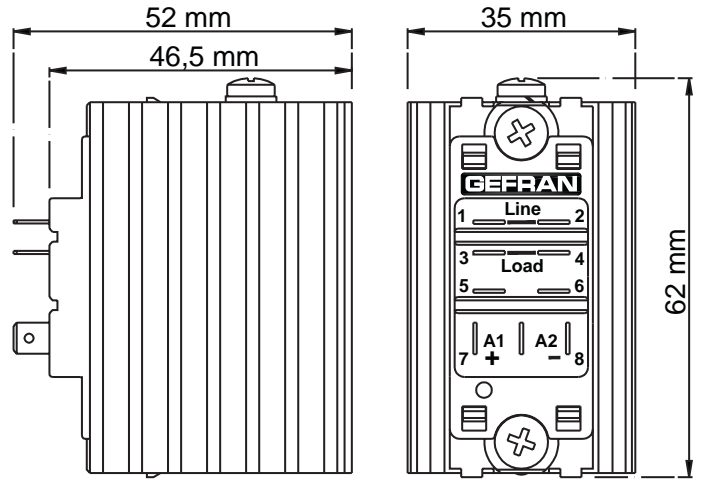

GTS-L 10/15

USE WITH PANEL MOUNTING (ACCESSORY FOR MODELS GTS-L 10/15A)

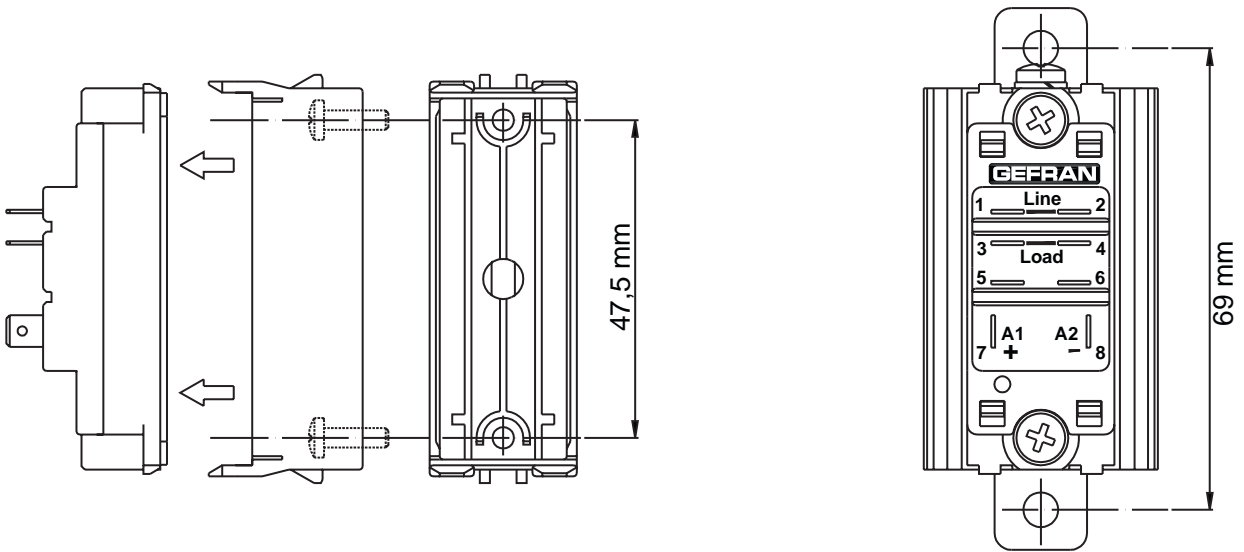

GTS-L 5

GTS-L 10/15

USE WITH DIN BAR ATTACHMENT (DIN 2 ACCESSORY)

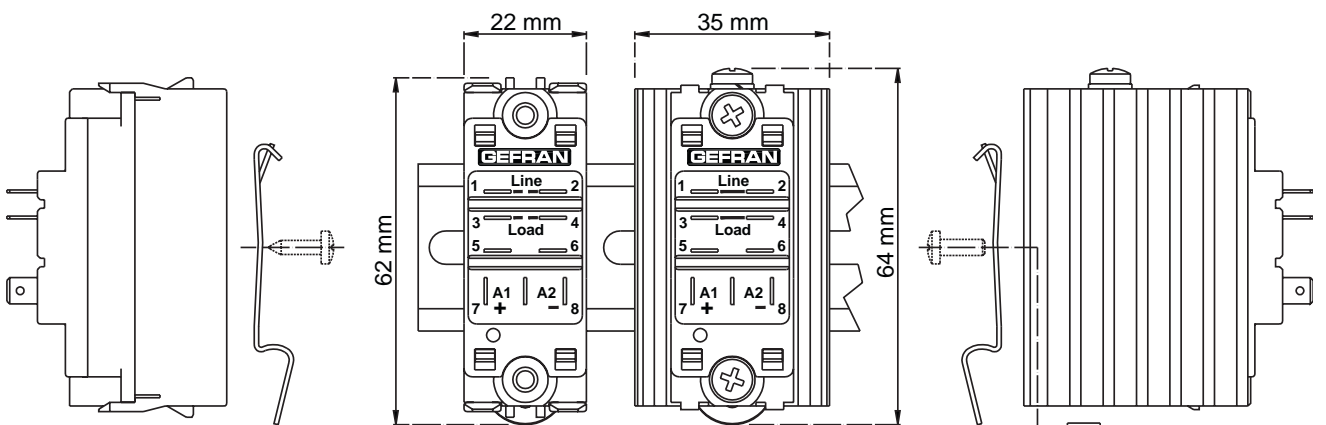

depth = 47 mm
weight = 50 g

depth = 59.5 mm
weight = 120 g

GTS-L 5

GTS-L 10/15

USE WITH BASE ATTACHMENT (ACCESSORY)

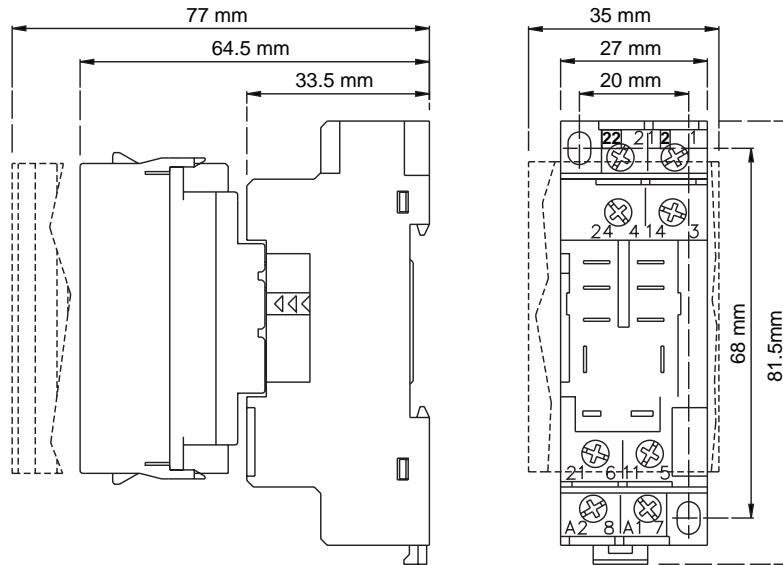

DISSIPATION CURVES

Rated current curves based on room temperature.

GTS - L 5 / 10 / 15

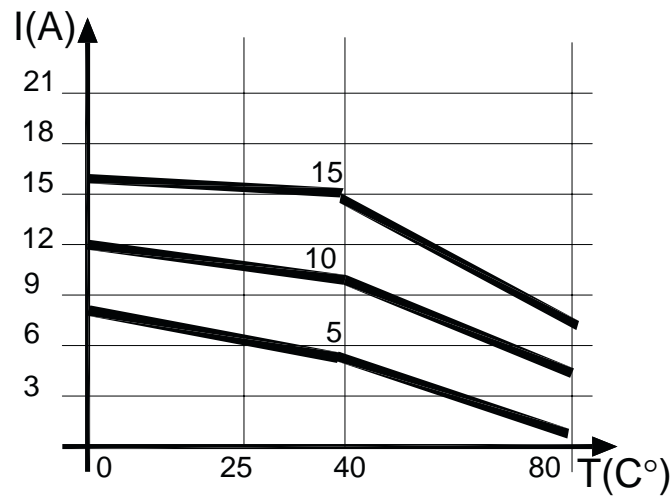

SAFETY AND PROTECTIONS

- The heatsink must be grounded on models GTS-L 10/15A.
- Attention: the GTS-L 5 uses a non-insulated heatsink protected by a grid.
Cut off power to the panel before removing the grid.
- With currents higher than 8 Amps, you have to connect the relay to the line and to the load by connecting both Line (1, 2) and Load (3, 4) terminals in parallel, according to the connection diagrams.
- The relay must be protected by an appropriate high-speed fuse suitable for the application with I_{2t} lower than that of the solid state relay.

CONNECTION EXAMPLES

Single-phase connection

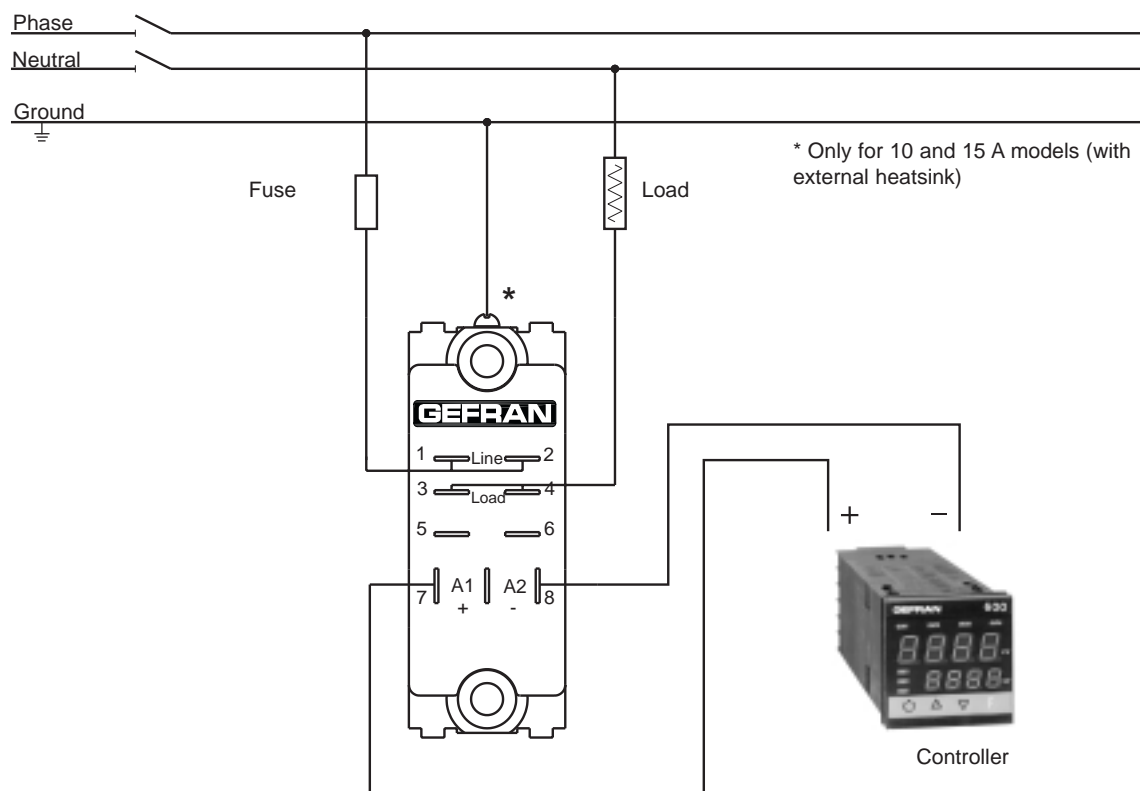

For other types of connection (3-phase star with neutral, 3-phase triangle or star without neutral on two phases) refer to the applications of the GS family of solid state power units.

TABLE OF TERMINAL AND LEAD CHARACTERISTICS

Size	CONTROL TERMINAL			POWER TERMINAL			GROUND TERMINAL •	
	Contact area (WxD) screw type	Pre-isolated wire terminal	Max. section conductor tightening torque	Contact area (WxD) screw type	Pre-isolated wire terminal	Max. section wire tightening torque	Contact area (WxD) screw type	Max. section conductor tightening torque
5A	-	Faston connector*	2.5mm ²	6,4x9	Faston connector*	2.5mm ²	-	-
10A	-	Faston connector*	2.5mm ²	6,4x9	Faston connector*	2.5mm ²	9x12 M4	2.5mm ² 1.3-1.8 Nm
15A	-	Faston connector*	2.5mm ²	6,4x9	Faston connector*	2.5mm ²	9x12 M4	2.5mm ² 1.3-1.8 Nm

(*) Female Faston 4.8 x 0.5 mm

(**) Maximum sections indicated refer to unipolar copper leads isolated in PVC.

Note: you have to use an **eye terminal** for the **ground** connection.

(WxD) = width x depth

ACCESSORIES

A wide range of accessories is available, such as fuses and fuse holders, relay bases, panel attachments and DIN guide attachments, thermostats.

To choose accessories, see the section "Solid state relays - Accessories".

ORDER CODE

Model		GTS-L		/	
Nominal current					
5Aac		5			
10Aac		10			
15Aac		15			
Nominal voltage					
230Vac		230			
440Vac		440			

Please contact GEFTRAN personnel for information on availability of codes.

•WARNINGS



WARNING: this symbol indicates danger.

Before installation, please read the following advices:

- follow the indications of the manual scrupulously when making the connections to the instrument.
- use a cable that is suitable for the ratings of voltage and current indicated in the technical specifications.
- if the instrument is used in applications where there is risk of injury to persons and damage to machines or materials, it is essential that it is used with an auxiliary alarm device.

It is advisable to verify frequently that the alarm device is functional even during the normal operation of the equipment.

- The instrument must NOT be used in environments where there could be the presence of dangerous atmospheres (inflammable or explosive).
- During continuous operation, the heatsink may reach 100°C and remain at a high temperature due to thermal inertia even after the device is switched off. Therefore, DO NOT touch the heat sink or the electrical wires.
- do not operate on the power circuit unless the main supply is disconnected.
- DO NOT open the cover if device is "ON"!
(use the holes in the cover for eventual re-calibration).

Installation:

- connect the device to the ground using the proper ground terminal.
- the power supply wiring must be kept separate from that of inputs and outputs of the instrument; always check that the supply voltage corresponds to that indicated on the instrument cover.
- evitare la polvere, l'umidità, i gas corrosivi, le fonti di calore.
- keep away from dust, humidity, corrosive gases and heat sources.
- The connection cable must be shorter than 3 meters if the current transformer is used.

Maintenance: Check the correct operation of the cooling fans at regular intervals; clean the ventilation air filters of the installation at regular intervals.

- Repairs must be performed only by specialized or appropriately trained personnel. Cut off power to the device before accessing internal parts.
- Do not clean the box with solvents derived from hydrocarbons (trichloroethylene, gasoline, etc.). Using such solvents will compromise the mechanical reliability of the device. To clean external plastic parts, use a clean cloth wet with ethyl alcohol or water.

Technical service : GEFTRAN has a technical service department. Defects caused by use not conforming to the instructions are excluded from the warranty.

GEFRAN spa reserves the right to make any kind of design or functional modification at any moment without prior notice



This device conforms to European Union Directive 2004/108/CE and 2006/95/CE as amended with reference to generic standards: **EN 61000-6-2** (immunity in industrial environment) **EN 61000-6-4** (emission in industrial environment) - **EN 61010-1** (safety regulations).



In Conformity with **UL508 - File: E243386**

GEFRAN

GEFRAN spa via Sebina, 74 - 25050 Provaglio d'Iseo (BS)
Tel. 03098881 - fax 0309839063 - Internet: <http://www.gefran.it>

DTS_GTS-L_0709_ENG